

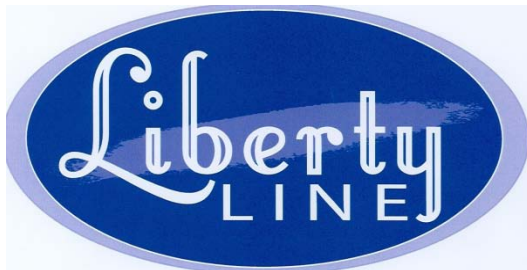

## ADA Compliant ¾" Threshold Gelcoat Handicap Showers



- CARE AND CLEANING
- WARRANTY
- INSTALLATION

Liberty Line employs independent testing to certify that products meet the requirements of ANSI Z124.1 or ANSI Z124.2, ANSI A117.1 2003, ADA, UFAS, and FHA/HUD - UM-73a. Flame Spread.

### Liberty Line

P.O. Box 1106 - 1610 James P. Rodgers Drive Valdosta, GA 31603  
(229) 333-0808

1.

## Read before installing to prevent voiding the warranty. Read and follow instructions or unit will not drain properly.

When installing the Liberty Line Gelcoat ¾" threshold showers the following precautions should be taken to help prevent damage during installation.

1. **Consult all local and state building codes for proper installation.**
2. It is advised that all barrier free units should be in a room with an outside floor drain to catch any over spray of water that may escape the unit.
3. Plan how unit will be brought into construction area and installed into framing pocket. (Drawing A-1 (Model 11383834) and A-2 (Model 11623634).
4. Prepare sub floor for the unit to sit into. (Drawing B)
5. Always have a framing member behind the flange. (Drawing C)
6. After slab preparation remove shipping blocks (referenced by orange label on back wall of unit and unit drawings) then preset unit to check level of unit and bottom drainage. Also place a piece of cardboard or carpet (soft side toward unit) in the unit to prevent damage.
7. **All barrier free shower units with wheelchair access into shower and handicap units with ¾" thresholds must be set in 45 minute fast set sheet rock mud. Fast Set mud should be mixed by the instructions on the bag. Don't use premixed sheet rock mud, grout, or cement under the unit.** (Drawing D)
8. **To insure proper draining temporary weight must be placed in the unit to prevent bottom warping. Look at drawing and gather materials needed before installing.** (Drawing D)
9. During cleanup, use a mild non-abrasive cleaning agent. Alcohol may be used on stubborn spots but do not use acetone or lacquer thinner since they may harm the finish.

2.

Drawing A - 1 Model 11383834 Shower Framing Pocket

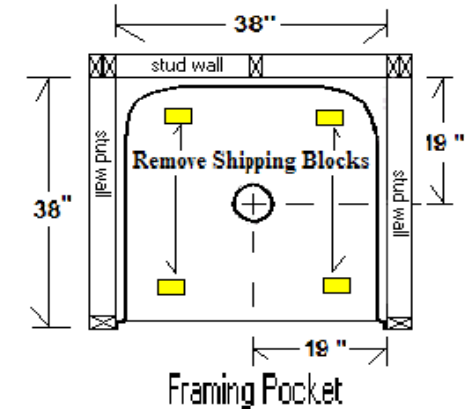

Drawing A - 2 – Model 11623634 Shower Framing Pocket

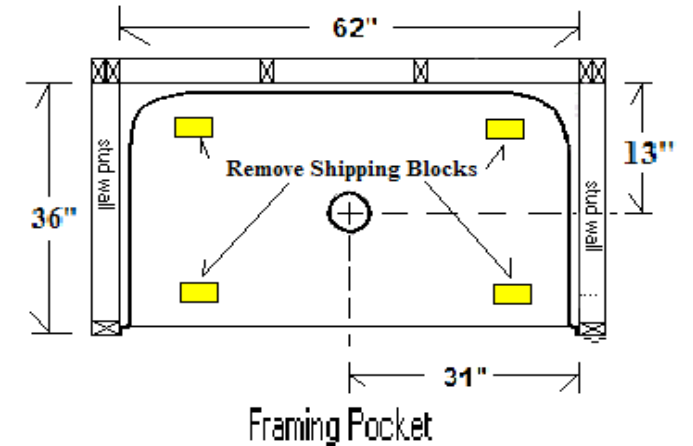

Drawing B – Slab Preparation

1. Chip concrete to allow the drain area room to set below grade.

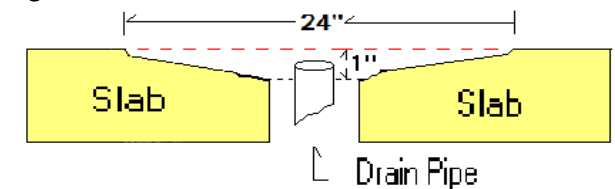

3.

## Drawing C – Flange Attachment – Overhead View

1. After slab preparation preset unit to check level of unit and bottom drainage.
2. Pre-drill flange holes to match screw size for attaching flange to wall and to speed the process of flange attachment after grout is placed for bottom support.

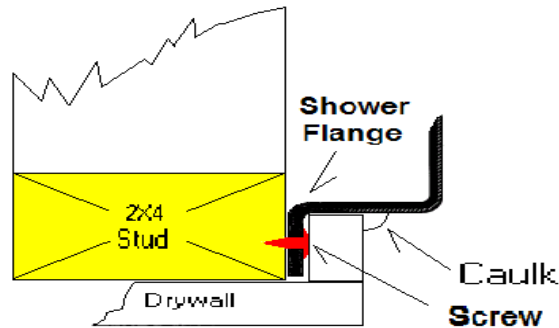

## Drawing D – 45 minute fast set sheet rock mud and Weight Placement for Proper Drainage and Correct Finished Floor Height for ADA

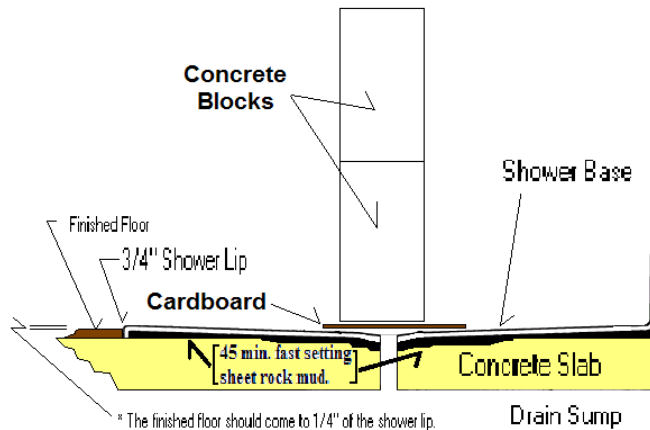

1. Before setting unit in 45 minute fast set sheet rock mud, have two 8" X 16" cement blocks and a 12" X 12" cardboard square at site to assure proper shower base drainage.

2. When ready to install the unit mix the mud according to the instructions on the bag, then pour the mud in the area the unit will sit. **Too much mud can cause the bottom of the unit to push upward and affect the drainage of the unit.**
3. Place the unit onto the mud and make sure the unit sits level and flush by attaching unit at pre drilled holes. (Drawing C)
4. **Place cardboard square over drain area and stack the blocks for weight immediately while mud is still wet to maintain floor slope to drain, check with level. Also check threshold and if it is bowed place cardboard and one of blocks on center of threshold to level.**
5. Inspect unit for high spots in the bottom and adjust the weight if needed to assure good drainage.
6. **Re-inspect the unit for a slope to the drain and a level threshold.**
7. Leave weight in place over 2 hours to allow mud to cure.
8. **The finished floor of the room should be built up to 1/2" below the top of the shower lip to comply with ADA.**

## Care and Cleaning

Liberty Line units are easy to keep clean and sparkling. Simply use warm water and a leading liquid cleaner. Never use abrasives as this will dull the surface of the unit or leave scratches. In cases where abrasives were used however, the finish can be restored by applying an automotive white polishing compound applied with a soft cloth, rubbing vigorously and then wiping off residue. Wax the area with prescribed procedures from a leading automotive wax manufacturer.

Stubborn stains can be removed with solvents such as alcohol or mineral spirits. In cases where this is necessary use the compounding and wax procedures shown above to finish the area where the solvents were used. Rubber bath mats may be used as long as they are removed after each use. Failure to remove the mat may cause blistering over time and is not covered by warranty.

Caution Note: When using cleaning solvents use all prescribed safety precautions.

## Limited Warranty

Liberty Line warrants to the original retail purchaser (herein "Original purchaser") that the Liberty Line unit (herein "the unit") to which this warranty is affixed is free from hidden defects in material and workmanship under normal use and service for (3) three years from date of invoice or as otherwise agreed to in writing by Liberty Line. Liberty Line shall not be liable under this warranty if, in its judgment, any person or persons installing the unit have reason to know of any defect therein prior to installation. Liberty Line's liability and the original purchaser's exclusive remedies under this warranty shall be limited to the onsite repair by an authorized repair agent, or at Liberty Line's option, either the refund of the full purchase price or replacement, without charge except for transportation and installation, of any part or parts of the unit which in Liberty Line's judgment are defective in material or workmanship. Any repaired or replaced part of the unit shall be warranted to the original purchaser only for the unexpired portion of the original warranty. This warranty shall not apply to any unit which has been repaired other than as indicated herein or which has been altered in any way which, in the judgment of Liberty Line affects its condition or performance, and is void if defect is caused by wind, storm, fire, accident, or similar casualty, or by improper use, installation, maintenance or storage. Replacement can only be authorized by a Liberty Line representative and only if the unit is beyond repair. Repairs made by unauthorized persons are not covered under warranty.

Except as required by law, Liberty Line shall not be liable to the purchaser or anyone else for damages, including, but not limited to, consequential damages and damages by reason of injury to any person, due to any defect in or malfunction of the unit or any part or parts thereof, or for any other reason.

Some states do not allow exclusion or limitation of incidental or consequential damages, so the above limitation or exclusion may not apply to you.

"To the extent allowable under specific state laws the obligations of Liberty Line hereunder are expressly granted in lieu of all warranties, whether express or implied, including but not limited to implied warranties or merchantability and fitness for a particular purpose, except that implied warranties shall be effective for (3) three years from the date of invoice of this unit, after said (3) three years all implied warranties are disclaimed and excluded from this warranty".

Some states do not allow limitations on how long an implied warranty lasts, so the above limitation may not apply to you.